



Glazed Fire-rated Doors and Fixed Assemblies

E 120

EI 30

EW 120



We are Hörmann, a pioneer in high performance doors across the world and No.1 door brand in Europe. Established in 1935, we adopt cutting-edge German technology to design, build and supply doors for Industrial, Commercial and Residential Applications.

We started our journey in India as Shakti Met-Dor(Now Shakti) in 1994 and have been operating as a Hörmann subsidiary since 2012, we have developed a reputation for excellence in the Indian market with high quality products, prompt delivery, and a service paradigm that has become an industry benchmark.

We have a Pan-India presence with sales and marketing offices spread across all major metros, and our manufacturing facility near Hyderabad is equipped to produce over 200,000 hollow metal doors and frames and over 10,000 Industrial doors per annum. All our doors come with varied options in Ironmongery, sizes and finishes, Incorporating the latest global standards in safety and security.

Our vision is to Introduce products and services that enrich customer experiences in the Residential, Commercial and Industrial spaces, built on the foundation of Innovation, Quality and Customer Fulfilment.



40 Countries
Worldwide



20 Million+
Doors Delivered



38 Factories
Across Europe, Asia & North America



6000+
Strong Workforce



100+
Sales Subsidiaries



Manufacturing Facility
in Hyderabad

Our presence in the global economy's key regions makes us a strong, future-oriented partner for industrial and public construction projects.



In-house Product Development

Continuously evolving functional and safety requirements demand ongoing advancements in construction and equipment, particularly in the realm of movable components like doors. In this domain, our proficient development teams consistently demonstrate their specialized expertise.



Highly Sophisticated Production Methods

We at Hörmann rely on the latest production technology at our specialised factories. Computer controlled operations ensure dimensionally accurate elements with perfectly fitted fittings and functional parts.



Fire Testing at Accredited Labs

Our new and further developments are constantly tested for required fire resistance and smoke tightness through fire tests at CBRI - India, Warrington, UK and UKAS approved labs. We continually test and certify the glass and fire-rated steel frame profiles as per IS3614 Part 2 & BS476 Part 22 standards. The knowledge gained from these ensures high fire protection for life and property.



Expert Building Support

Experienced specialists within our customer oriented sales organisation accompany you from the planning stage, through technical clarification up to the final building inspection. Expert fitting is guaranteed by experienced Hörmann fitters and the specialised trained staff of our reliable partners.

THINGS TO KNOW ABOUT OUR PRODUCT MARKING:

Barcode Tracking: For easy Identification and Product/Installation/Issue Tracking.



Unique Customer Order No. for easy tracking and Identification

IS/BS Label: Information on the Fire Label, Unique Identification Number.



120 minutes Un-Insulated Fire Door Tested as per IS 3614 & BS 476 → Fire Rating
:040-27840394/5 → Testing Standard
823/30 → Unique Serial No. Provided for Easy Tracking

Certifire Label: Information on the Fire label, unique Identification Number.



Certifire File No. that can be tracked online

Fire Rating
Unique Serial No. Provided and audited by the Certification body

Hörmann is committed to highest standards of safety, performance, and quality. Our Glazed Fire Doors are tested, evaluated or certified as per Nationally and Internationally recognized standards at premier testing labs. They are tested to withstand extreme conditions for longer durations to ensure complete safety.



केन्द्रीय भवन अनुसंधान संस्थान, रुड़की
CENTRAL BUILDING RESEARCH INSTITUTE, ROORKEE
(A Constituent Establishment of CSIR)

*Actual pictures of door testing.



Fully Glazed Fire-rated Doors have opened new avenues for architectural creativity. Transparent and aesthetically appealing, they match up with interior/exterior glazing and integrate seamlessly with the designers' intent.

DESIGN HIGHLIGHTS

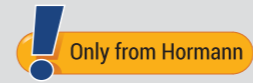

- Largest door tested in India in this category, available in both insulated (E) and uninsulated (EI/EW)
- Slim profile with integral astragal
- Range of glasses: 8 mm, 10 mm, 11 mm, 12 mm and 14 mm
- Fire rated lock from Hörmann in latched and unlatched conditions
- Only manufacturer to test a door in unlatched condition
- Any Certifire approved Fire-rated Glass can be used on our glazed systems
- Types of fire glass used: Borosilicate and Inter-layered
- Tested in Warrington, UK and CBRI, India
- Toughened and frosted glass options are also available
- Non Fire-rated Door options are also available for general application. They provide higher strength and durability when compared to UPVC and Aluminium Doors

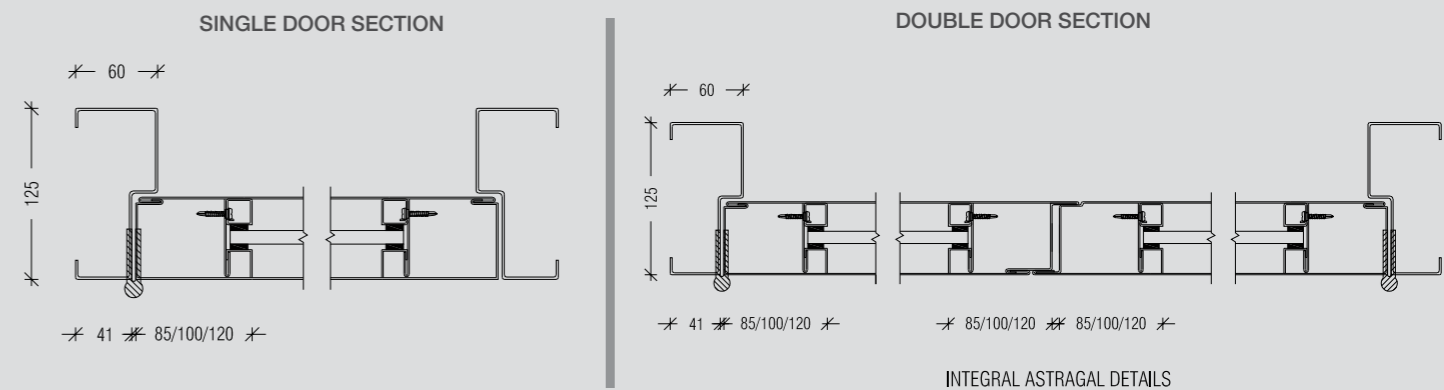

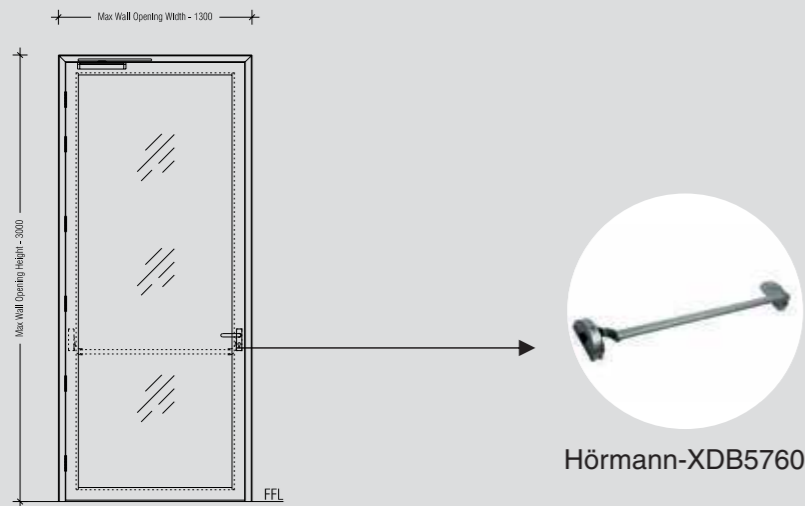

- Panic Bolting Technology ensures that people can get out of the Danger Zone at any time, even in a Panic Situation.
- One push on the Horizontal Activation Element is all it takes and the door springs open.

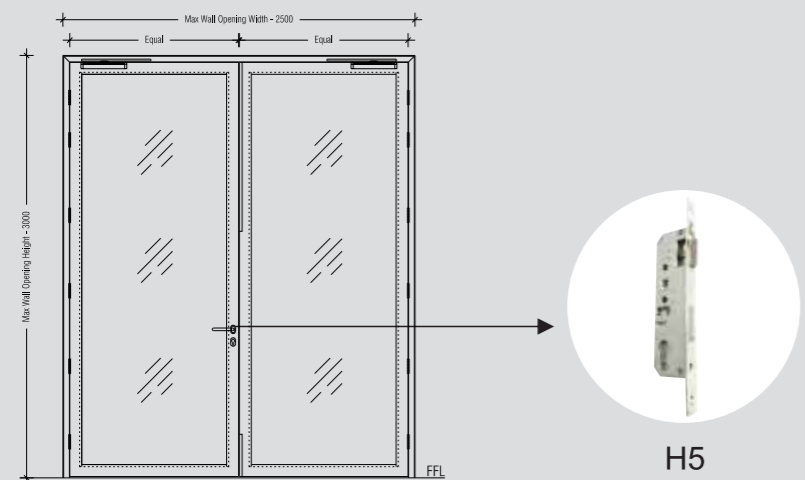

APPLICATIONS

Commercial Complexes | Offices | Schools | Healthcare Facilities | Luxury Retail Outlets | Shopping Malls | Hotels | Government Offices | Public Transport Terminals | Banks

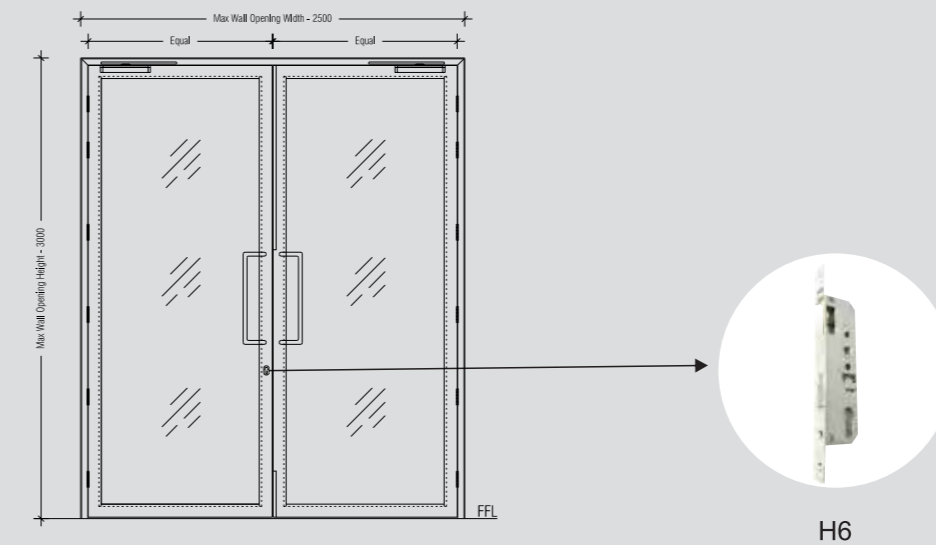
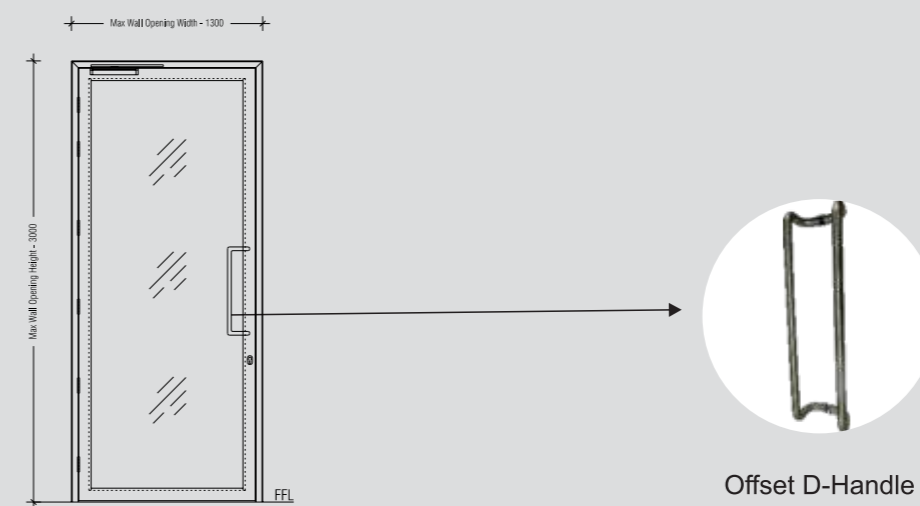

- Unlatched Doors are used in High Traffic Areas
- India's First Fire tested unlatched fully Glazed Door
- Slim lock Specially designed for Hörmann Profile
- Offset 'D' Handle - Specially Designed for Slim Profile Section

APPLICATIONS

Museums | UPS & Data Server Rooms | Telecom Centers | Lift Lobbies | External Facades | Smoke Barrier System | Fire Partitions | Fire Exit Corridors | Staircases | Escalator Containment | Elevator Containment



HINGES

The standard ball bearing butt hinge for Fire-rated and Smoke-tight Doors are designed to take weight up to 120 kgs.



LOCK

As standard, all Hörmann Fire-rated and Smoke-tight Doors are equipped with Mortise Sashlock - H11 or Mortise dead lock - H4. Optionally, we offer panic device - Hörmann 1211.

*Suitable for 120 mm Stile



LEVER HANDLE SET

As standard, we offer all door sets with an offset stainless steel lever LT001 /handle set with a steel core including a cylinder rose escutcheon.



CLOSING DEVICE [HDC035]

As standard, all Fully Glazed Fire-rated Doors are equipped with a slide rail overhead door closer on hinge size



Available in varied styles
Choose as per your Requirement

On the Forefront of Innovation
Benefit from Our Range of Innovative Products

SPECIAL STYLE OPTIONS

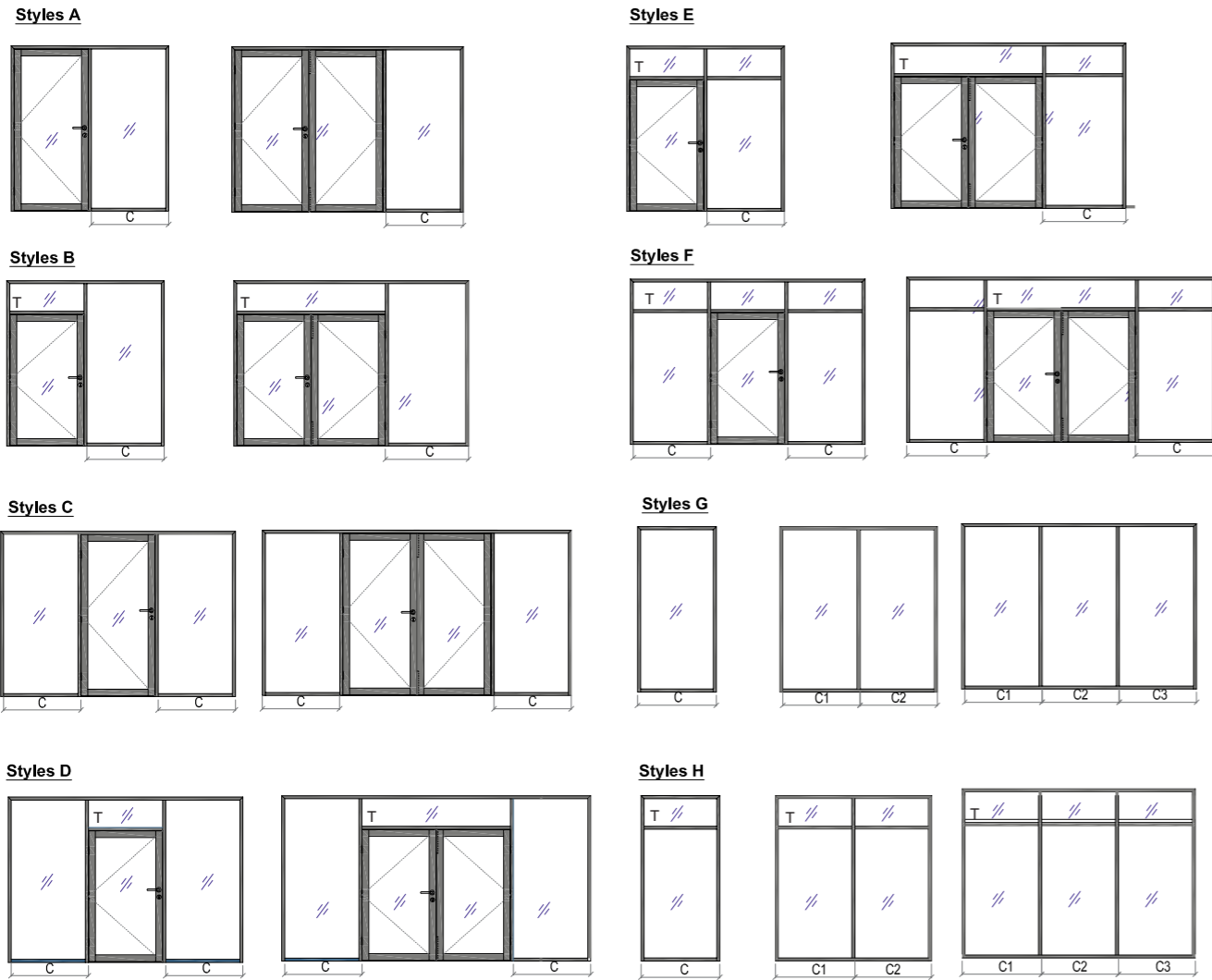

Please consult us in advance for any other solutions.

RAL COLOURS

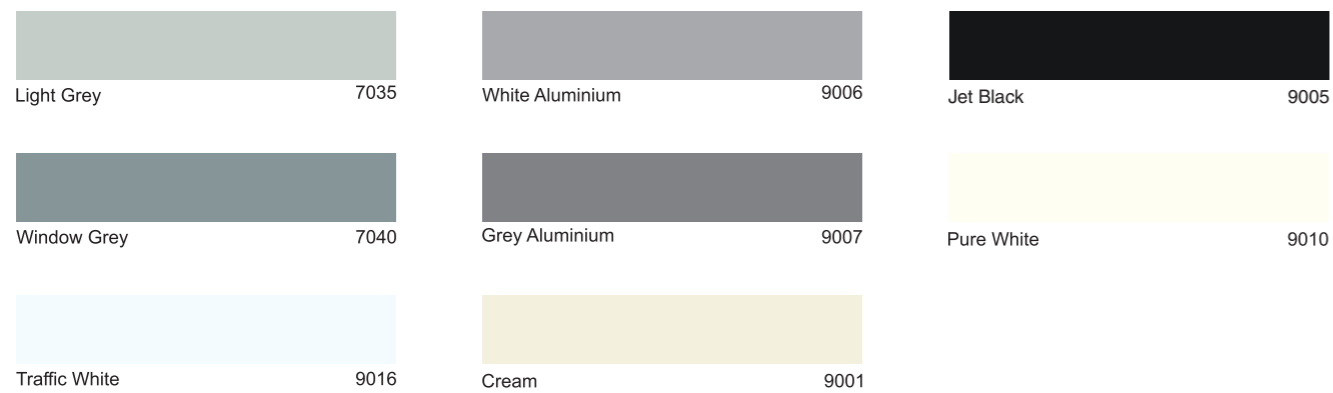

COMMERCIAL:

- Fire rated doors 
- Glazed fire rated doors
- Clean room doors
- Multi-purpose doors
- Fire rated auto sliding door



INDUSTRIAL:

- Sectional overhead doors
- High speed roll up doors
- Insulated rolling shutters
- Fire rated rolling shutters
- Dock levelers
- Dock shelters



RESIDENTIAL:

- Main entrance doors
- Bed room doors
- Balcony doors
- Bathroom doors



PERIMETER PROTECTION:

- Security bollards
- Boom barriers
- Tyre killers





Eco-Conscious

At Hörmann, we believe in playing our role in contributing towards a sustainable tomorrow. We support energy conservation, green revelation and eco-friendly products. More than 60% of the power requirement at our production facility is fulfilled by our own solar power unit. Our factory is under certification for Platinum rating by Indian Green Building Council.

Corporate Social Responsibility

Every time we achieve a little, we build a doorway to help others. The guiding principle is to improve the quality of the society and the environment that sustains us, and create a sustainable well-being.

As a socially responsible company, we contribute every year to build a better community, help the unprivileged and contribute for the greater good of the planet.



Our Presence in India





Hörmann KG Amshausen, Germany



Hörmann KG Antriebstechnik, Germany



Hörmann KG Brandis, Germany



Hörmann KG Brockhagen, Germany



Hörmann KG Dissen, Germany



Hörmann KG Eckelhausen, Germany



Hörmann KG Freisen, Germany



Hörmann KG Ichtshausen, Germany



Hörmann KG Werne, Germany



Hörmann Alkmaar B.V., Netherlands



Hörmann Legnica Sp. z o.o., Poland



Hörmann Beijing, China



Hörmann Tianjin, China



Hörmann LLC, Montgomery IL, USA



Hörmann Flexon LLC, Burgettstown PA, USA



Shakti Hormann, India



Hyderabad Plant, India



Jaipur Plant, India

RESIDENTIAL DOORS | COMMERCIAL DOORS | INDUSTRIAL DOORS | LOADING BAY TECHNOLOGY | PERIMETER CONTROL SYSTEMS



Shakti Hormann Pvt. Ltd.

H.No.2-67/1, Gagillapur, Dundigal Municipality,
Medchal (Malkajgiri) District – 500 043.
Telangana, India

E: sales@shaktihormann.com
www.shaktihormann.com

+91 81422 36677



Platinum Rated Green Facility



An ISO 9001:2015, ISO 14001:2015 and
ISO 45001:2018 certified company